

SAMSUNG

VRF

Technical Data Book

**DVM S Eco for America
(R410A, 60Hz, HR)**



Model : AM***NXMDCR/AA

Nomenclature

Outdoor Unit

Model Name

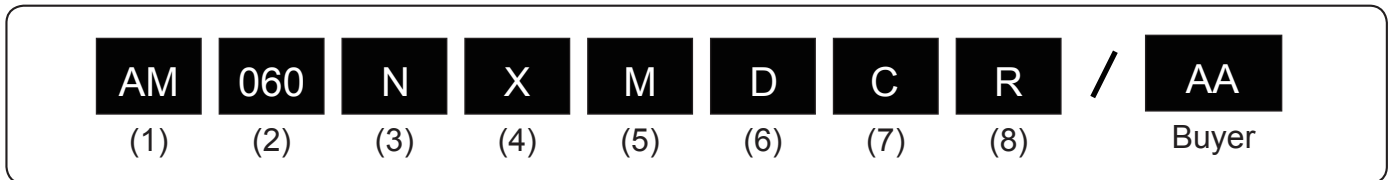

(1) Classification

AM	DVM
----	-----

(2) Capacity

kBTu/h (3 digits)

(3) Version

K	2016
M	2017
N	2018

(4) Product Type

X	Outdoor Unit
N	Indoor Unit

(5) Product Notation

M	DVM S Eco
---	-----------

(6) Feature

A	Standard + General Temp.+ MODULE
H	High EER + Low Temp + Module
D	STANDARD+GENERAL Temp. + NON MODULE

(7) Rating Voltage

E	1Ø, 220~240V, 50Hz
G	3Ø, 380~415V, 50Hz
H	3Ø, 380V, 60Hz
C	1Ø, 208V~230V, 60Hz

(8) Mode

H	Heat Pump
R	Heat Recovery

2. Specification

Type			DVM S ECO	DVM S ECO	DVM S ECO	DVM S ECO	
Model Name			AM036NXMDCR/AA	AM048NXMDCR/AA	AM053NXMDCR/AA	AM060NXMDCR/AA	
Power Supply			Φ, #, V, Hz	1, 2, 208 ~ 230, 60	1, 2, 208 ~ 230, 60	1, 2, 208 ~ 230, 60	
Mode			-	Heat Recovery	Heat Recovery	Heat Recovery	
Performance	TON	TON	3	4	4.5	5	
	Capacity	Cooling ^{1)*} Heating ^{2)*}	Btu/h Btu/h	38,000 42,000	48,000 54,000	53,000 61,000	60,000 66,000
Maximum number of connectable indoor units	Total capacity of the connected Indoor Units	Min.	EA	8	9	10	
		Max.	EA	19	24	27	30
Power	Power Input (Nominal)	Cooling ^{1)*}	kW	3.1	4.2	5.3	5.2
		Heating ^{2)*}	kW	3.4	4.4	5.4	5.3
	Current Input (Nominal)	Cooling ^{1)*}	A	15.0	20.3	25.6	23.0
		Heating ^{2)*}	A	16.4	21.3	26.1	23.5
	MCA	A	23.0	29.0	34.0	32.0	
MOP	A	40.0	50.0	50.0	50.0		
COP	EER (Nominal Cooling, US)	(Btu/h)/W	12.3	11.4	10.0	11.5	
	COP (Nominal Heating)	W/W	3.62	3.60	3.31	3.65	
	EER ^{3)*}	(Btu/h)/W	11.20	10.20	9.45	10.90	
	COP ^{3)*}	W/W	3.00	3.00	2.95	3.54	
	SEER ^{3)*}	-	17.2	17.2	17.5	17.1	
HSPF ^{3)*}	-	9.5	10.4	10.0	10.9		
Casing	Material	Cabinet	-	EGI steel plate	EGI steel plate	EGI steel plate	EGI steel plate
		Base	-	GI steel plate	GI steel plate	GI steel plate	GI steel plate
Heat exchanger	Type		-	Fin & Tube	Fin & Tube	Fin & Tube	Fin & Tube
	Material	Fin	-	Al	Al	Al	Al
		Tube	-	Cu	Cu	Cu	Cu
Fin Treatment		-	Anti-corrosion	Anti-corrosion	Anti-corrosion	Anti-corrosion	
Compressor	Type		-	Twin BLDC Rotary	Twin BLDC Rotary	Twin BLDC Rotary	Inverter Scroll
	Output		kW × n	4.04 x 1	4.04 x 1	4.04 x 1	4.96 x 1
	Model Name		-	UG5TK5450FJX x1	UG5TK5450FJX x1	UG5TK5450FJX x1	DS-GB052FBVA
	Oil	Type	-	PVE	PVE	PVE	PVE
Initial Charge		cc (fl oz)	1700 (57.4)	1700 (57.4)	1700 (57.4)	1100 (37.2)	
Fan	Type		-	Propeller	Propeller	Propeller	Propeller
	Discharge direction		-	Horizontal	Horizontal	Horizontal	Horizontal
	Quantity		ea	2	2	2	2
	Air Flow Rate		CMM	110	110	110	135
			CFM	3,885	3,885	3,885	4,767
			l/s	1,833	1,833	1,833	2,250
External Static Pressure	Max.	mmAq	-	-	-	-	
		Pa	-	-	-	-	
Fan Motor	Model		-	BLDC Motor	BLDC Motor	BLDC Motor	BLDC Motor
	Output x n		W	125 x 2	125 x 2	125 x 2	139 x 2
Piping Connections	Liquid Pipe		Type	Braze connection	Braze connection	Braze connection	Braze connection
			Φ,mm(inch)	9.52 (3/8")	9.52 (3/8")	9.52 (3/8")	9.52 (3/8")
	Gas Pipe		Type	Braze connection	Braze connection	Braze connection	Braze connection
			Φ,mm(inch)	19.05 (3/4")	19.05 (3/4")	19.05 (3/4")	19.05 (3/4")
	Discharge Gas Pipe (HR Only)		Type	Braze connection	Braze connection	Braze connection	Braze connection
			Φ,mm(inch)	15.88(5/8")	15.88(5/8")	15.88(5/8")	15.88(5/8")
	Heat insulation		-	Both liquid and gas pipes	Both liquid and gas pipes	Both liquid and gas pipes	Both liquid and gas pipes
Piping length (ODU-IDU)	Max. [Equiv.]	m (ft)	150 [175] (492 [574])	150 [175] (492 [574])	150 [175] (492 [574])	150 [175] (492 [574])	
Piping length (1st Branch-IDU)	Max.	m (ft)	40 (131)	40 (131)	40 (131)	40 (131)	

2. Specification

Type				DVM S ECO	DVM S ECO	DVM S ECO	DVM S ECO
Model Name				AM036NXMDCR/AA	AM048NXMDCR/AA	AM053NXMDCR/AA	AM060NXMDCR/AA
Piping Connections	Total piping length (System)	Max.	m (ft)	300 (984)	300 (984)	300 (984)	300 (984)
	Level difference (ODU in highest position)	Max.	m (ft)	50 (164)	50 (164)	50 (164)	50 (164)
	Level difference (IDU in highest position)	Max.	m (ft)	40 (131)	40 (131)	40 (131)	40 (131)
	Level difference (IDU-IDU)	Max.	m (ft)	15 (49)	15 (49)	15 (49)	15 (49)
Wiring connections 4)*	Communication	Minimum	mm ²	0.75	0.75	0.75	0.75
		Remark	-	F1,F2	F1,F2	F1,F2	F1,F2
Refrigerant	Type			R410A	R410A	R410A	R410A
	Factory Charging		kg	3.2	3.2	3.3	3.7
			lbs	7.1	7.1	7.3	8.2
Sound 5)*	Sound Pressure	Cooling	dB(A)	50	51	53	58
		Heating		52	53	55	59
	Sound Power			66	67	69	76
External Dimension	Net Weight		kg	97	97	100	125
			lbs	213.8	213.8	220.5	275.6
	Shipping Weight		kg	107	107	110	135
			lbs	235.9	235.9	242.5	297.6
	Net Dimensions (WxHxD)		mm	940 x 1,210 x 330	940 x 1,210 x 330	940 x 1,210 x 330	940 x 1,420 x 330
			inch	37.01 x 47.64 x 12.99	37.01 x 47.64 x 12.99	37.01 x 47.64 x 12.99	37.01 x 55.91 x 12.99
Shipping Dimensions (WxHxD)		mm	995 x 1,388 x 426	995 x 1,388 x 426	995 x 1,388 x 426	995 x 1,578 x 426	
		inch	39.17 x 54.65 x 16.77	39.17 x 54.65 x 16.77	39.17 x 54.65 x 16.77	39.17 x 62.13 x 16.77	
Operating Temp. Range	Cooling		°F	23 ~ 118	23 ~ 118	23 ~ 118	23 ~ 118
	Heating		°F	-13 ~ 75	-13 ~ 75	-13 ~ 75	-13 ~ 75

NOTE

- Specifications may be subject to change without prior notice.
 - 1)* Nominal cooling capacities are based on;
 - Indoor temperature : 80°F DB, 67°F WB
 - Outdoor temperature : 95°F DB, 75°F WB, Equivalent refrigerant piping : 25ft, Level differences : 0ft
 - 2)* Nominal heating capacities are based on;
 - Indoor temperature : 70°F DB, 60°F WB
 - Outdoor temperature : 47°F DB, 43°F WB, Equivalent refrigerant piping : 25ft, Level differences : 0ft
 - 3)* Certified performance under Unitary Small HP AHRI Standard 210/240.
 - Combination Indoor Units : Ducted indoor units.
 - 4)* Select wire size based on the value of MCA
 - 5)* Sound power level is an absolute value that a sound source generates.
 Sound pressure level is a relative value, depending on the distance and acoustic environment.
 Sound values are obtained in an anechoic room.
 Sound values of multi combination are theoretical values based on sound results of individual installed units.
- These products contain R410A which is fluorinated greenhouse gas.

3. Electrical Characteristics

Capacity		Model	Power Supply				Voltage Range[V]		Nominal Running Current [A]		Current [A]		ODU Fan Motor [kW]
Ton	Btu/h		Φ	#	Hz	Voltage	Min. (-10%)	Max. (+10%)	Cooling	Heating	MCA	MOP	
3	38,000	AM036NXMDCR/AA	1	2	60	208~230	187.2	253	15.0	16.4	23.0	40.0	0.250
4	48,000	AM048NXMDCR/AA	1	2	60	208~230	187.2	253	20.3	21.3	29.0	50.0	0.250
4.5	53,000	AM053NXMDCR/AA	1	2	60	208~230	187.2	253	25.6	26.1	34.0	50.0	0.250
5	60,000	AM060NXMDCR/AA	1	2	60	208~230	187.2	253	23.0	23.5	32.0	50.0	0.278

 **NOTE**

- MCA : Minimum circuit amperes
- MOP : Maximum Overcurrent Protective Device (A)
- Select wire size based on the value of MCA

4. Dimensional Drawing

AM036NXMDCR/AA, AM048NXMDCR/AA, AM053NXMDCR/AA

Units : mm [inches]

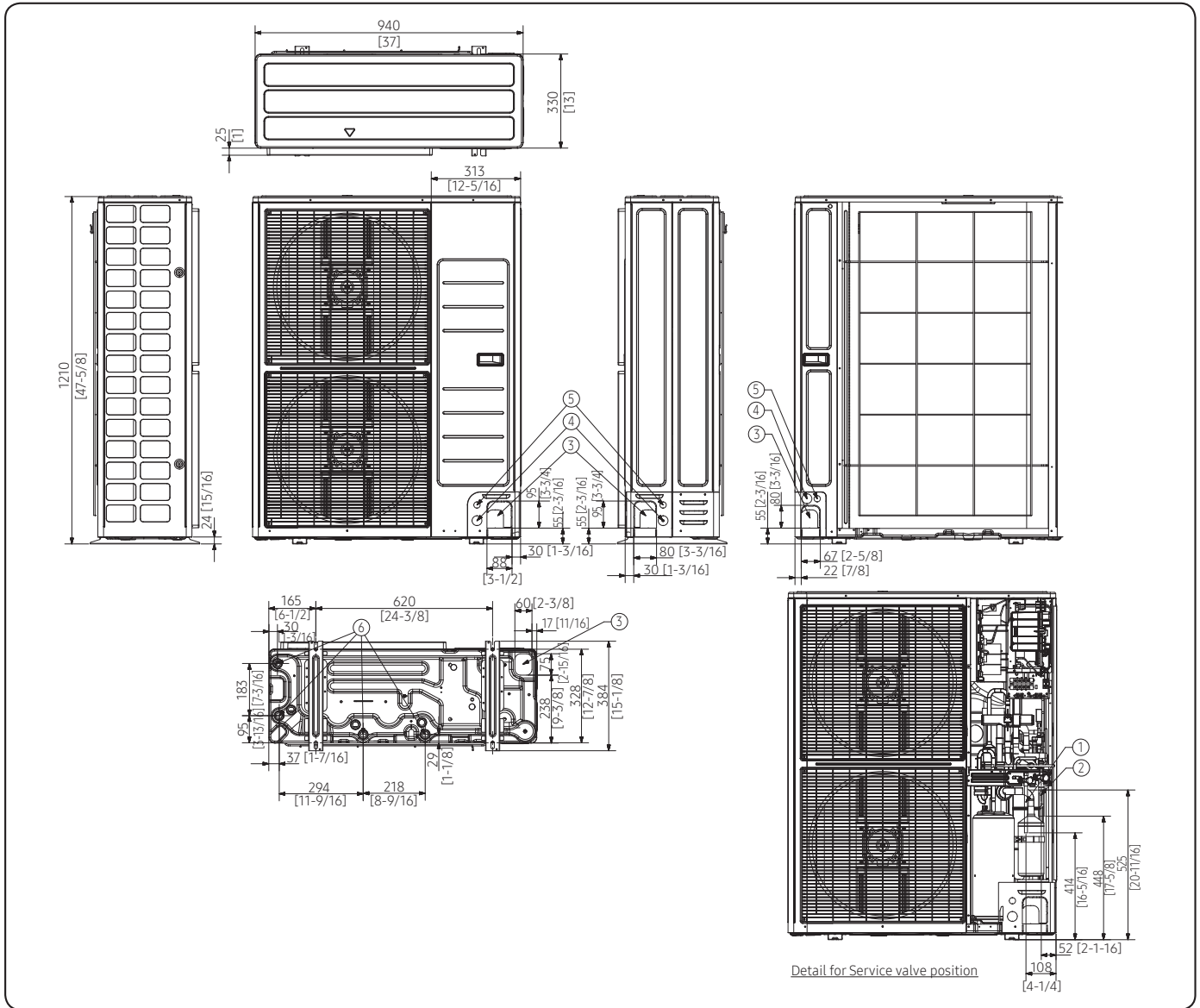

NO	Name	Description
1	Refrigerant liquid pipe	Φ9.52 (Φ3/8)
2	Refrigerant gas pipe	19.05 (3/4")
3	Knockout hole for pipe intake	Front / Side / Rear / Bottom
4	Power wiring conduits	Front / Side / Rear, Φ34 (Φ1-3/8)
5	Communication wiring conduits	Front / Side / Rear, Φ22 (Φ7/8)
6	Drain holes	Connect with the provided drain plug.

6. Electrical Wiring Diagram

AM***NXMDCR/AA

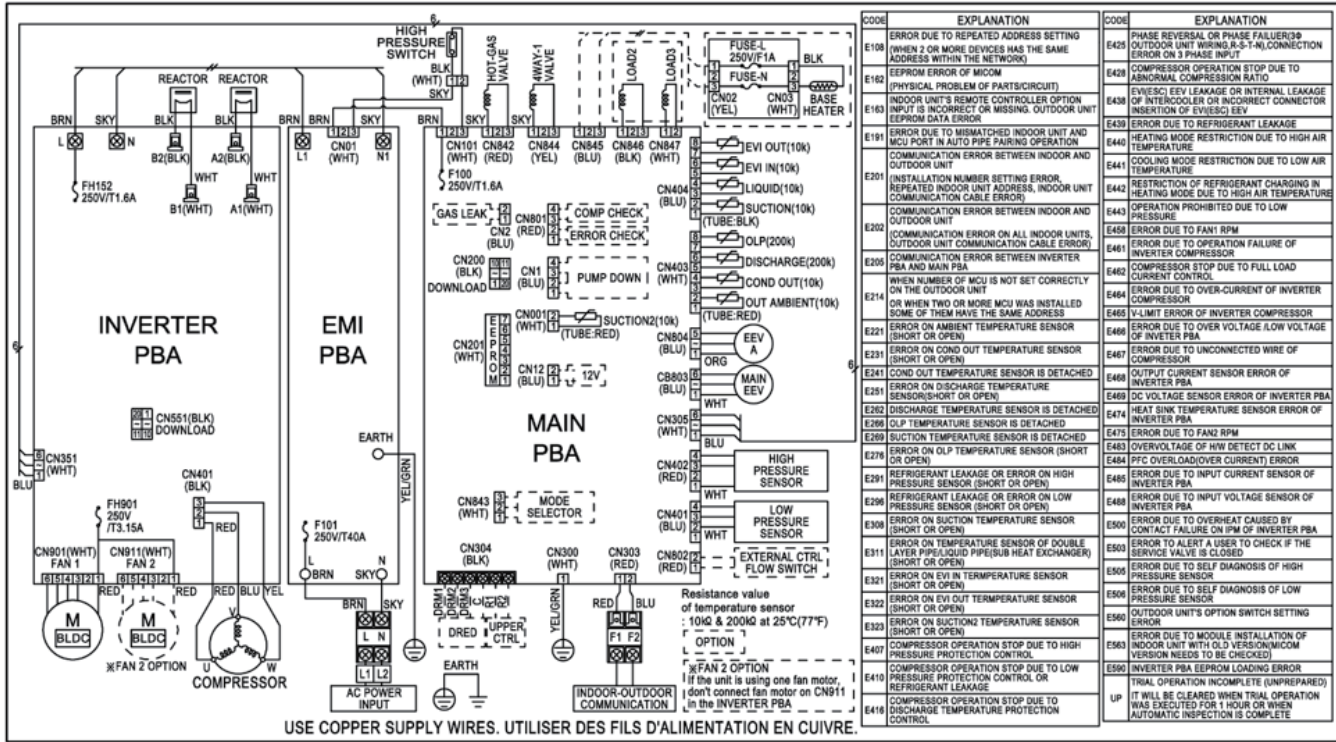

INV PBA1	Printed circuit board(inverter)	MAIN EEV	electronic expansion valve	LIQUID(10K)	Thermistor LIQUID(10K)
EMI PBA	Printed circuit board(emi)	EEV A	electronic expansion valve	OLP(200K)	Thermistor (OLP)
MAIN PBA	Printed circuit board(main)	EVI-OUT(10K)	Thermistor (Enhanced Vapor Injection_out)	ERROR/COMP EXT	Connector (Output ERROR/COMP EXT CON)
HOTGAS1 V/V	Solenoid valve(HOTGAS1)	EVI-IN(10K)	Thermistor (Enhanced Vapor Injection_in)	HIGE PRESSURE	PRESSURE SENSOR
4WAY V/V	Solenoid valve(4WAY)	SUCTION1(10K)	Thermistor (SUCTION1)	LOW PRESSURE	PRESSURE SENSOR
COMP	Motor (compressor)	OUT(10K)	Thermistor (Air)	F1/F2	OUT TO INDOOR COMMUNICATION
M BLDC	BLDC Motor (fan1)	COND(10K)	Thermistor (COND.)		
M BLDC	BLDC Motor (fan2)	DIS1(200K)	Thermistor DIS1(200K)		
250V/T40A	FUSE(EMI PBA)	SUCTION2(10K)	Thermistor (SUCTION2)		

NOTE

- This wiring diagram applies only to the outdoor unit.
- Colors BLK: black, RED: red, BLU: blue, WHT: white, YEL: yellow, BRN: brown, SKY: skyblue
- When operating, don't shortcircuit the protection device (High Pressure switch)
- For connection wiring indoor-outdoor transmission F1-F2.
- Protective earth(SCREW), : connector, $\frac{N}{x}$: The quantity

7. Sound Data

Summary

Capacity		Model	Sound Pressure dB (A)		Sound Power dB(A)
Ton	Btu/h		Cooling	Heating	
3	38,000	AM036NXMDCR/AA	50	52	66
4	48,000	AM048NXMDCR/AA	51	53	68
4.5	53,000	AM053NXMDCR/AA	53	55	69
5	60,000	AM060NXMDCR/AA	58	60	76

NOTE

- Specifications may be subject to change without prior notice.
- Sound Pressure Level
 - Sound pressure level is obtained in an anechoic room.
 - Sound pressure level is a relative value, depending on the distance and acoustic environment.
 - Sound pressure level may differ depending on operation condition.
 - dBA = A-weighted sound pressure level
 - Reference acoustic pressure 0 dB = 20μPa
- Sound Power Level
 - Sound power level is an absolute value that a sound source generates.
 - dBA = A-weighted sound power level.
 - Reference power : 1pW.
 - Measured according to ISO 3741.

9. Piping Diagram

AM036/048/053NXMDCR/AA

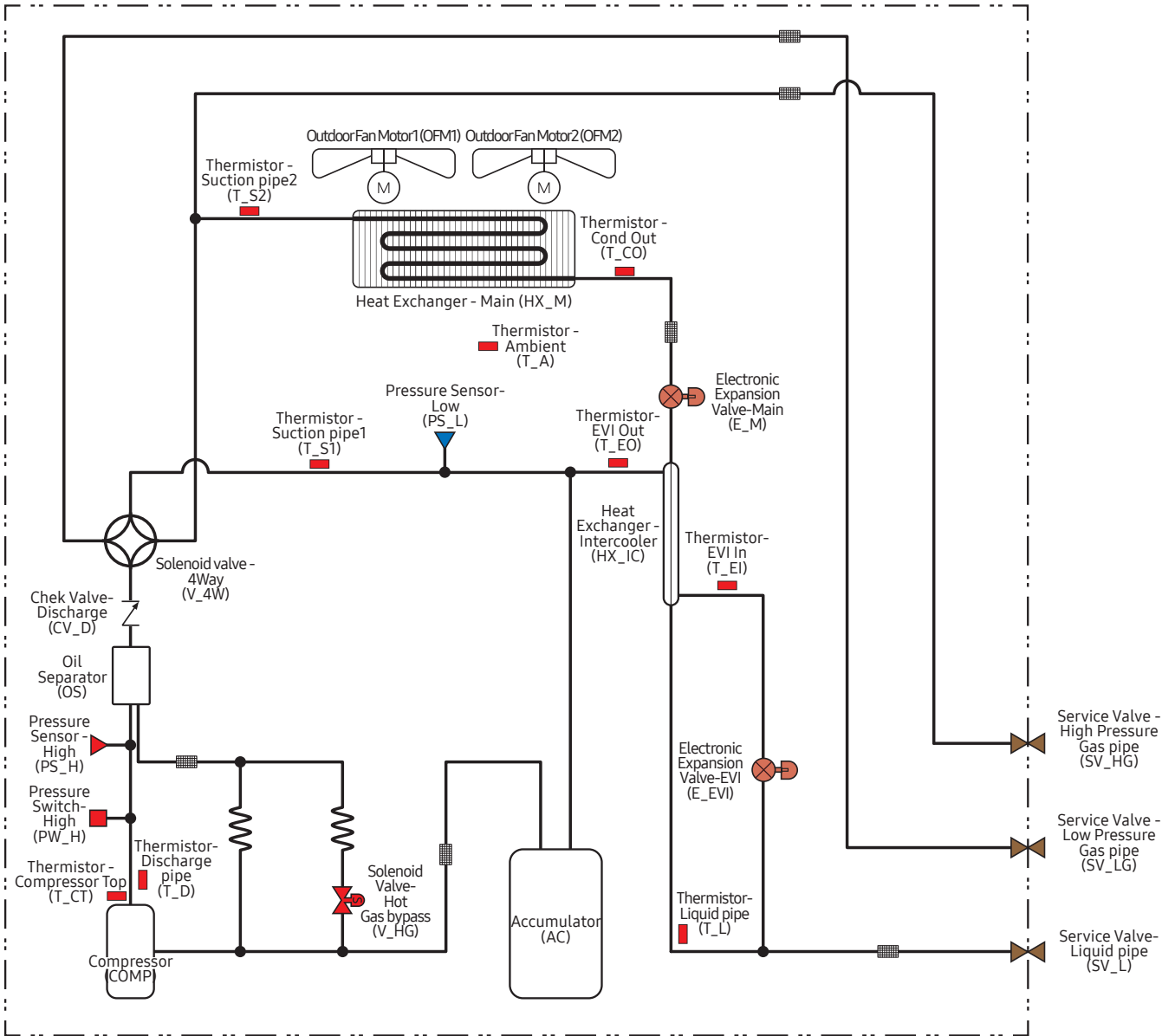

The background of the page is a complex geometric pattern of overlapping triangles and polygons in various shades of blue, ranging from a deep navy blue to a lighter, medium blue. The pattern is abstract and modern, filling the left and top portions of the page.

2020.12
Ver.1.5

Samsung Electronics Co., LTD.

Head Office (Suwon Korea) 129, Samsung-Ro, Yeongtong-Gu, Suwon City, Gyeonggi-Do, Korea 16677
Website : www.samsung.com, <https://partnerhub.samsung.com> Email : airconditioner@samsung.com
Images and data in this book may subject to change without prior notice.